

# TES 200

DIAMETRO FORO/hole diameter: 150/280 mm  
 PROFONDITA'/depth: 200 mt  
 TIRO/pull: 16 ton  
 COPPIA ROTARY/torque: 1300 kgm  
 giri/min: 0/250 RPM  
 POTENZA MOTORE/engine power: 200 HP  
 ARGANO PRINCIPALE/main winch: 3 ton  
 MORSA/clamp (DIAM MIN/MAX): 80/300 mm

A RICHIESTA/optional:  
 POMPA FANGO/mud pump-POMPA SCHIUMA/foam  
 pump- COMPRESSORE/compressor-  
 OLEATORE/oiler- CARICATORE/loader

VERSIONI/configurations:  
 CINGOLATO/on crawler - AUTOCARRO 3  
 ASSI/on 3 axles truck - BASAMENTO/base -  
 RIMORCHIO/trailer

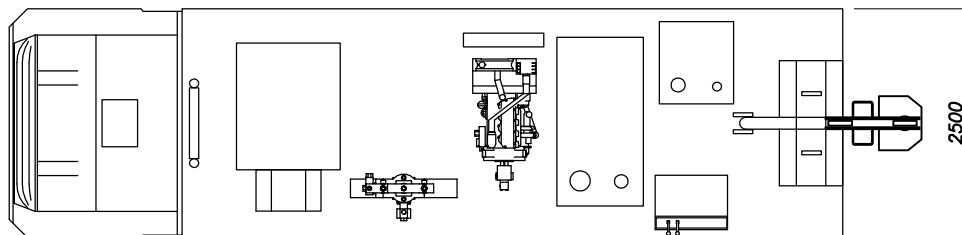
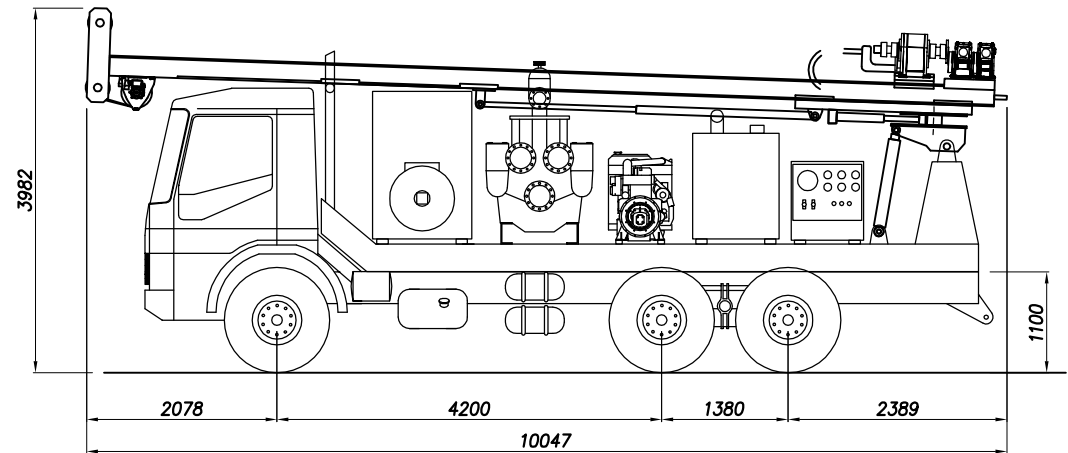
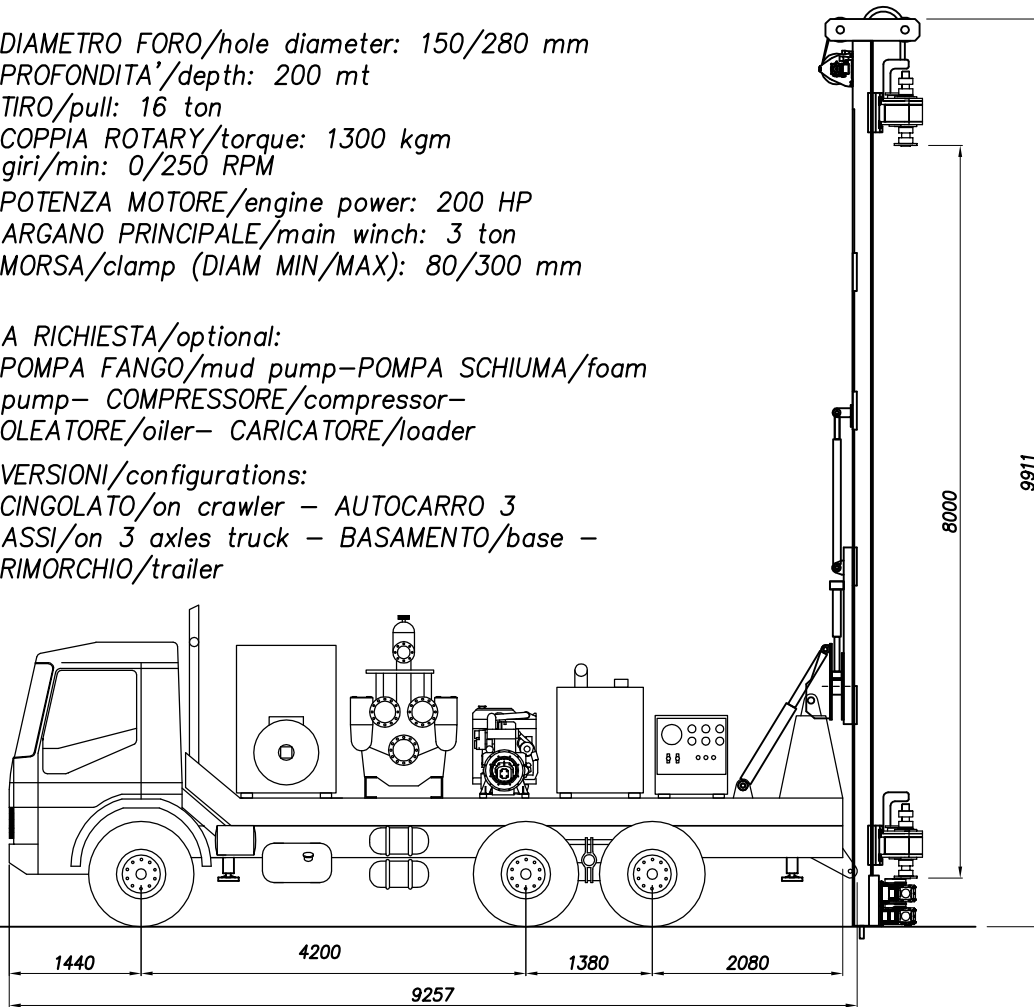

TES CAR srl  
 via Flaminia II, 18  
 60027 OSIMO - AN - ITALY  
 Tel: 0039.071.7231883  
 0039.071.714372  
 Fax: 0039.071.714416