





# TES 40 compact

Perforatrice Idraulica TES 40 compact  
TES 40 compact Hydraulic Drill  
Foreuse Hydraulique TES 40 compact  
Perforadora Hidráulica TES 40 compact



**TES CAR SRL**  
Macchine da trivellazione  
Hydraulic drilling rigs  
Via Flaminia II, 18  
60027 - Osimo (AN) - ITALIA  
TEL. : 0039 - 071 72 31 883  
0039 - 071 71 43 72  
FAX : 0039 - 071 71 44 16  
web-site: [www.tescar.com](http://www.tescar.com)  
e-mail: [info@tescar.com](mailto:info@tescar.com)

## Dati tecnici / Technical data / Données techniques / Datos técnicos

				
<b>Slitta a catena per aste da 1,5 m</b>	<b>Feed chain for 59,05 inc rods</b>	<b>Chariot à chaîne pour tiges 1,5 mt</b>	<b>Corredera a cadena para varillas 1,5 mt</b>	
Tiro	Pull	Retrait	Tiro	<b>2000 kg - 4400 lb</b>
Corsa	Stroke	Course	Carrera	<b>2500 mm - 98,42 inc</b>
Corsa trasversale	Sideway travel	Course transversale	Carrera transversal	<b>330 mm - 13 inc</b>
Controslitta	Counterslide	Contre-chariot	Carrera de columna al suelo	<b>400 mm - 15,74 inc</b>
Avanzamento con motoriduttore a catena	Feeding with chain and gear motor	Avancement avec chaîn et réducteur	Avance con cadena y reductor	
Argano	Winch	Treuil	Cabrestante	<b>1000 kg / 2200 lb</b>
<b>Testa di rotazione idraulica</b>	<b>Hydraulic rotary head</b>	<b>Tête de rotation hydraulique</b>	<b>Cabeza de rotacion hidráulica</b>	
Coppia	Torque	Couple	Par	<b>500 kgm - 3616,5 ftslb</b>
Motore a cilindrata variabile con riduzione giri	Variable flow motor with r.p.m. Reduction	Moteur à portée variable avec réducteur de tours	Motor a caudal variable con reductor de revoluciones	<b>0 ÷ 300 r.p.m.</b>
<b>Morsa idraulica e doppia morsa</b>	<b>Hydraulic clamp and double clamp</b>	<b>Étau hydraulique et double étau</b>	<b>Mordaza simple o doble</b>	<b>Ø76 ÷ Ø200</b>
4 stabilizzatori idraulici	4 hydraulic stabilizers	4 stabilisateurs hydrauliques	4 estabilizadores hidráulico	
Regolazione giri rotary, pressione e avanzamento	Pressure, feeding and speed adjustments	Réglage pression, avancement et vitesse	Regulación de presión avance y velocidad	
Passaggio acqua e aria con testina di adduzione	Air / water swivel head	Tête d'adduction pour air et eau	Inyección de aire y agua	
Traliccio con ralla regolabile con comando idraulico	Mast orientation with hydraulic adjustment	Mât avec auréolaire à réglage hydraulique	Corredera giratoria con comando hidráulico	
<b>Motore</b>	<b>Engine</b>	<b>Moteur</b>	<b>Motor</b>	<b>Fiat IVECO</b>
Potenza	Power	Puissance	Potencia	<b>80 CV - 59 kW - 58,17HP</b>
Pulsante d'arresto	Stop button	Bouton d'arrêt	Botón de parada	
Pompa principale	Main pump	Pompe principal	Bomba principal	<b>150 l/min - 39,6 US gal/min</b>
Pompa di servizio	Service pump	Pompe pour services	Bomba de servicio	<b>41 l/min - 10,86 US gal/min</b>
Serbatoio olio	Oil tank	Réservoir d'huile	Depósito de aceite hidráulico	<b>100 l / 26.4 US gal</b>
Scambiatore di calore	Heat exchanger	Échangeur de chaleur	Radiator de aceite	
<b>Dimensioni per il trasporto</b>	<b>Dimensions for transport</b>	<b>Dimensions pour le transport</b>	<b>Dimensiones para el transporte</b>	
Larghezza	Width	Largeur	Ancho	<b>1510 mm / 59,44 inc</b>
<b>Peso</b>	<b>Weight</b>	<b>Poids</b>	<b>Peso</b>	<b>6000 kg / 13200 lb</b>

- Tutti i dati tecnici sono indicativi. La TES CAR si riserva il diritto di modificarli opportunamente.
- Technical data are indicative only. TES CAR reserves the right to introduce changes without prior notice.
- Les caractéristiques techniques sont indicatives. TES CAR se réserve le droit de les modifier sans préavis.
- Todos los dato tecnicos son indicativos. La TES CAR se reserva la facultad de modificarlos oportunamente

# TES

# 40

## compact

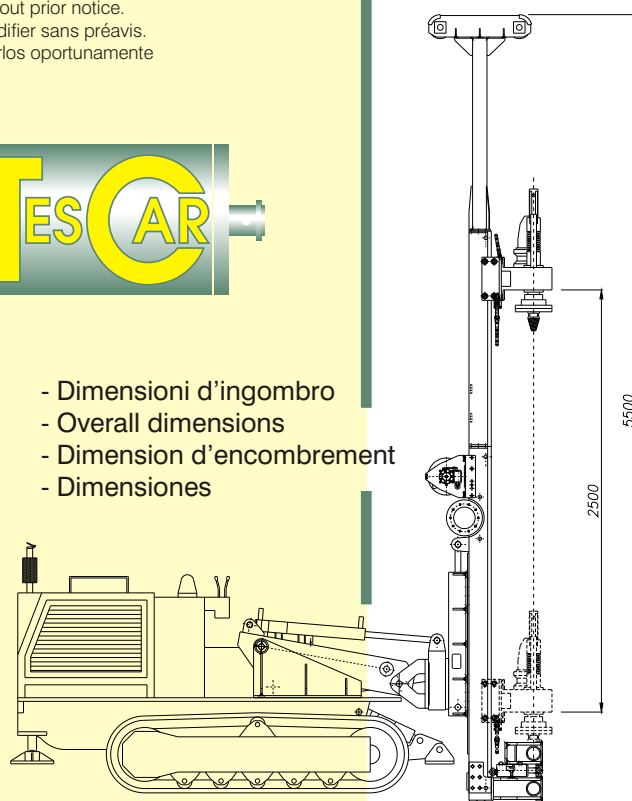
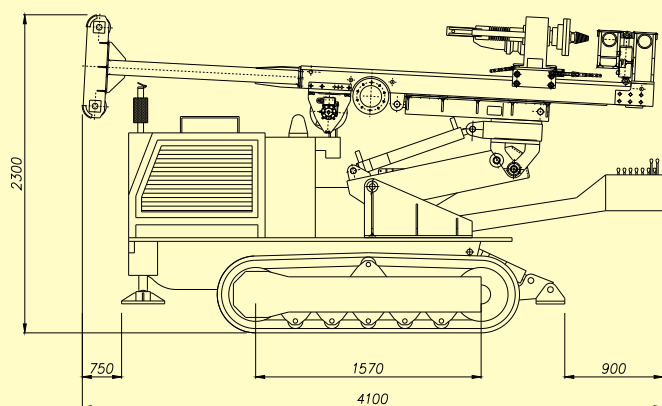

- Dimensioni d'ingombro
- Overall dimensions
- Dimension d'encombrement
- Dimensiones